



## **Resysta – Gold and Platinum Decking Installation Guidelines**

---

**NOTE:** Proper planning of the deck layout is essential for ease of installation of deck boards and deck components. Thoroughly read the following deck assembly instructions and obtain all necessary building permits prior to starting your installation. Decide finishing and trimming options prior to starting the project to ensure deck projections and finishing detail are uniform for all sides of the deck. Installation is the sole responsibility of the installer. Resysta assumes no responsibility whatsoever with respect to the installation. The information contained herein is provided for guidance purposes only and should not be relied upon as any absolute representation by Resysta.

### **Safety Tips:**

1. Always check for power, gas, and water lines before digging.
2. Always wear safety glasses when operating power equipment.

### **Assembly Tips:**

1. Substructure should be plumbed, square, solid and sound.
2. Ensure firm soil and adequate water drainage.
3. Use table 1.1 “Joist Spacing Requirements” as a guide in determining joist spacing for decking installation.
4. Overhang deck boards to a maximum of 1”.
5. All holes should be pre-drilled.
6. Flashing is necessary if decking is to be attached to a dwelling. Uncovered decks should be sloped approximately 2 degrees away from dwelling or other walls for adequate water drainage.
7. Only use construction fastening material and hardware suitable for outdoor use (e.g. stainless steel screws).
8. Always consider the linear expansion of Resysta, which is dependent on the temperature but not air humidity. See Table 1.2 “Resysta Expansion” for more information.
9. Cut-off pieces and/or abrasive dust must be disposed separately. Please comply with regulations of your local waste management provider. You may under no circumstances burn Resysta.
10. “Window shims” are a good way to maintain consistent spacing between abutting boards. Not only will this add to the visual appeal, but it will also allow natural board expansion to occur without interference. The illustration on the next page represents an end to end condition.

## Code Compliant Joist Spacing

| Part Number | Part Description                       | Joist Span (in) |
|-------------|--|-----------------|
| RES0106xx   | Platinum Decking 1" x 5½" (1" x 5.51") | 16              |
| RES0108xx   | Platinum Decking 1" x 7½" (1" x 7.48") | 16              |
| RESG0106xx  | Gold Decking 1" x 5½" (.976" x 5.51")  | 16              |

Table 1.1 "Joist Spacing Requirements"

**Requirement for Joist Spacing** – If the decking is being installed in a location where the air gap below the decking is equal to or less than 6" from the underside of the decking substructure to the ground / solid structure the joist spacing must be reduced to 12" center-to-center for all decking profiles.

If the decking boards are being installed diagonally, 12" spacing between joists is also required.

**Recommendation for Joist Spacing** – If the decking is being installed in hot climates in the southern states it is recommended to reduce the spacing to 12" center-to-center. 12" spacing between joists is also recommended for the commercial application due to the higher weight capacity being required.

## Expansion / Contraction of Decking

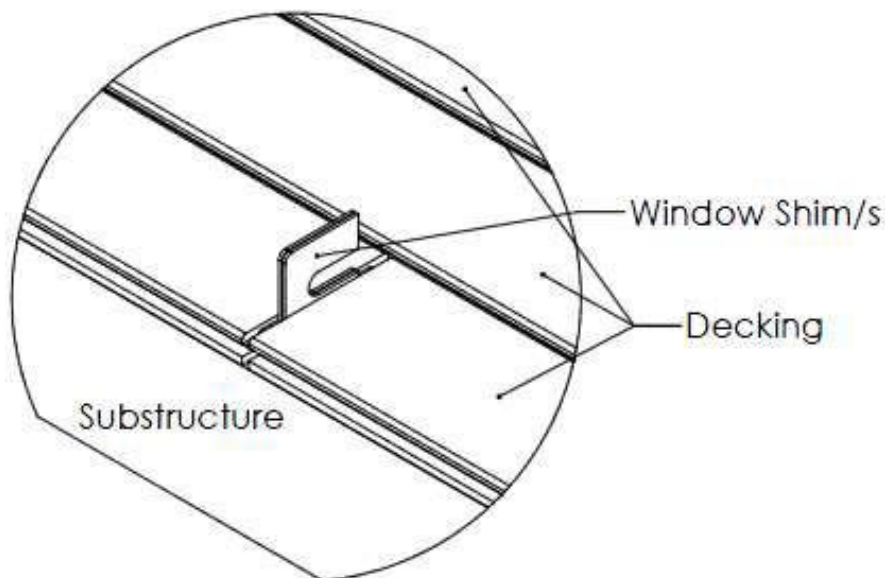

Figure 1 - Window Shims are the preferred method for creating and maintaining consistent spacing between boards.



| <b>Resysta Expansion – Contraction Guide</b>  |                   |                   |                  |
|---|-------------------|-------------------|------------------|
| <b>Profile Length</b>   | <b>12 ft.</b>     | <b>16 ft.</b>     | <b>20 ft.</b>    |
| <b>Expansion / Contraction amount (approx. 0.3% over 90°F variation in temperature)</b> | 7/16"<br>(0.432") | 9/16"<br>(0.576") | 3/4"<br>(0.720") |

**Expansion – Contraction:** Average expected expansion – contraction (this can vary based on geographical region)

| <b>Resysta Decking Board Gap Guide</b>             |                                     |              |              |               |                 |
|--|-------------------------------------|--------------|--------------|---------------|-----------------|
| <b>Temperature at Installation</b>                 | <b>End-to-End of Decking Boards</b> |              |              |               | <b>Wall Gap</b> |
|  | <b>Below 30 °F</b>                  | <b>60 °F</b> | <b>90 °F</b> | <b>120 °F</b> |                 |
| <b>Amount for Decking Profile Length of 12 ft.</b> | 7/16"                               | 1/4"         | 1/16"        | 0"            | 1/4"            |
| <b>Amount for Decking Profile Length of 16 ft.</b> | 9/16"                               | 3/8"         | 3/16"        | 0"            | 5/8"            |

**Table 1.2 "Resysta Expansion" – Ensure a steady material temperature when cutting the boards to size, i.e. the cutting has to be done under constant conditions, e.g. inside or in shade.**

Always consider linear expansion of Resysta profiles during the installation of decking products. If temperatures fluctuate during the installation the gaps placed between the ends of the boards and the ends of a wall or fascia board must change with the temperature. Use the guide above to gap boards during installation.

**Expansion – Contraction Tips:**

- 1) Control Piece – at the start of the day cut a length of board that is desired to be installed and keep this board in the same area as the cutting and storage of the remaining boards. This board will be a “Control Piece” to reference to when cutting other boards to be installed. Throughout the day the “Control Piece” can be referenced to and the saw cuts adjusted accordingly as the boards expand and/or contract. Heat from the sun will cause Resysta boards to expand so if the material is stored in the shade keep the “Control Piece” in the shade as well.

**Example:** If 12ft boards and 16ft boards are being installed cut one 12ft board and one 16ft board at the start of the day. Reference these boards throughout the day and adjust the cutting of the other boards to match

- 2) Control Gap – at the start of the installation place the decking gap according to Table 1.2 and mark the first gap made. This gap will be a “Control Gap” to reference to when gapping the remaining boards to be installed. Throughout the installation reference back to this “Control Gap” to match the other gaps being installed. This will ensure that all the gaps installed are the same.



## Installation – Procedure

### SECTION 1 – Substructure

Frame the substructure and secure the post supports in compliance with local building codes. Ensure that the joist structure provides for deck boards attachment on centers not exceeding the requirements laid out in table 1.1 “Joist Spacing Requirements.” On decks where two deck boards will be used end-to-end, a minimum of two joists must be used to accommodate the fastening of the deck boards to the substructure where the boards meet. Prior to installing the Resysta deck boards, fasten the railing post supports to the wood substructure. Do not mount the post supports on top of the Resysta decking. Please refer to the railing installation instruction manual for suggested railing post support attachment options.

### SECTION 2 – Fastening Resysta Decking

Resysta decking is to be installed with the Resysta Plastic Clips. List of profiles suitable to be installed with the Resysta Clip is outlined below in table 2.1.

| Decking Profile | Plastic Clip |
|-----------------|--------------|
| Gold Decking    | ✓            |
| Platinum 5-1/2” | ✓            |
| Platinum 7-1/2” | ✓            |

**Table 2.1** - Installation with Resysta plastic clip (see Section 4).

### SECTION 3 – Selecting Starting Options

Resysta decking allows the installer to choose from two different starting techniques. The type of installation and location of the installation will affect which starting condition can be used. If installing a deck where the ends of the deck boards will be against a house or wall, use the proper wall gap spacing before securing the deck boards to the substructure.



### STEP 3.1 – Dowel Start Condition

It is recommended to pre-cut the dowels to your specific needs to prevent unnecessary cutting after installation which may damage the decking surface. Pre-Drill the deck board at the screw location using a 1/8" drill bit, drill through both top and bottom walls. Drill a larger hole through the top wall only with a drill bit sized for the Resysta dowel; 29/64" (12mm) drill bit works best. Screw in the #10 x 2-1/2" stainless steel screw through the bottom.

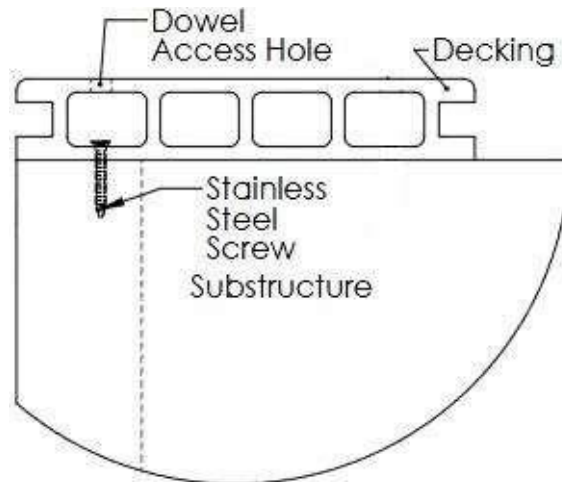

Do this for every joist location making sure that the screw is installed into the open cavity closest to the starting edge of the deck board. Do not install a screw closer than 1" from the end of the deck board.

**Requirement** – It is recommended to drill the 1/8" hole through both walls and flip the deck board over to make the slot. The 1/8" hole can be used as a guide to mark and cut the slot in the bottom wall of the deck board. Use the 1/8" hole as the center of the deck and make the slot 3/16" wide and 1" long.

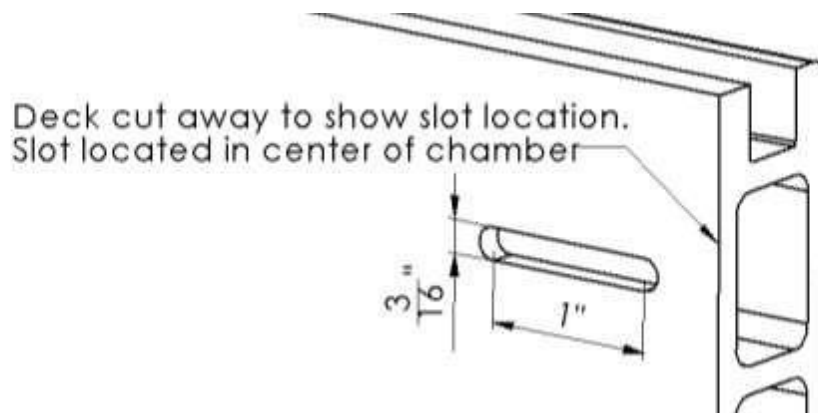



**Recommendation** – A 3/16” slot cutter or router bit can be used to make the slot in the deck board. If a larger slot is used a washer needs to be used and can be inserted into the cavity of the end of the deck board after the board is prepared for installation. In either case it is recommended to use a button head or other style screw head that will sit flat against the wall of the deck board.

### STEP 3.2 – RESCLIPSS125W Clip Start Condition

Attach the Starter Clip to the frame substructure running parallel to the deck board using supplied stainless steel screws. Install the Clip at every joist location. Place the lower lip of the deck board inside the Starter Clip and lock it in. Secure the deck board with a Vinyl Clip on the opposite side and continue with the Vinyl Clip until the whole deck is installed.

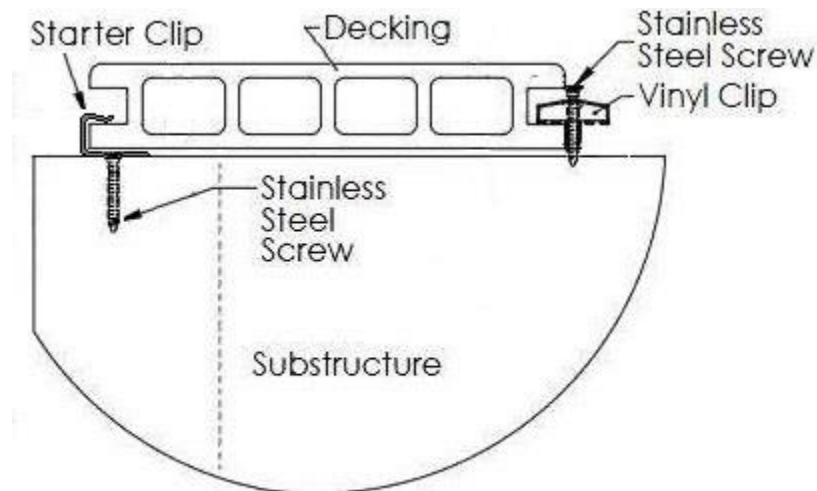
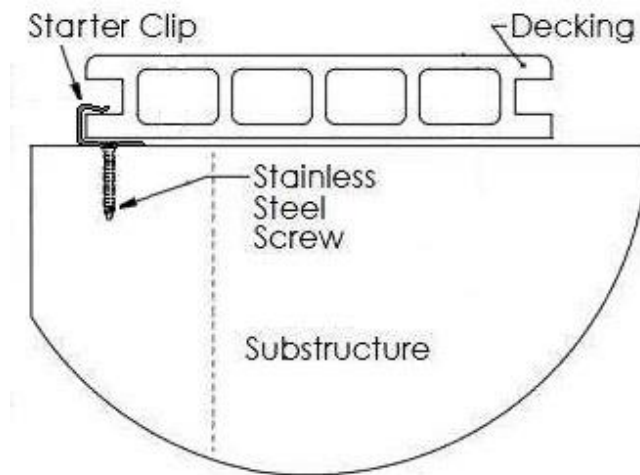



## SECTION 4 – Installation of Deck Boards

### “Vinyl Clip Method”

**STEP 4.1** – Follow one of the start conditions in Section 3 to secure the first board to the framing joist. Make sure to follow the Gap Guide in Table 1.2 if the deck board is against a house or wall.

**STEP 4.2** – When installing a single board in the row, locate the joist closest to the center of the deck board. Pre-drill the deck board in the groove at the side of the deck board using a 1/8” drill bit. Install a #10 x 2- 1/2” stainless steel screw to secure the deck board to the substructure. Do this for the center joist only to allow for expansion/contraction of the deck board in both directions.

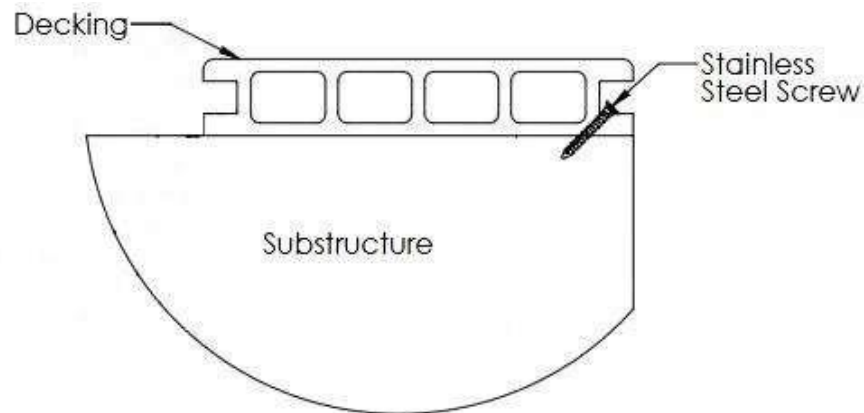

**Note** – When 2 boards are installed in the same row, they need to be hard fastened at the butt joints to allow expansion in opposite directions, away from the butt joints.

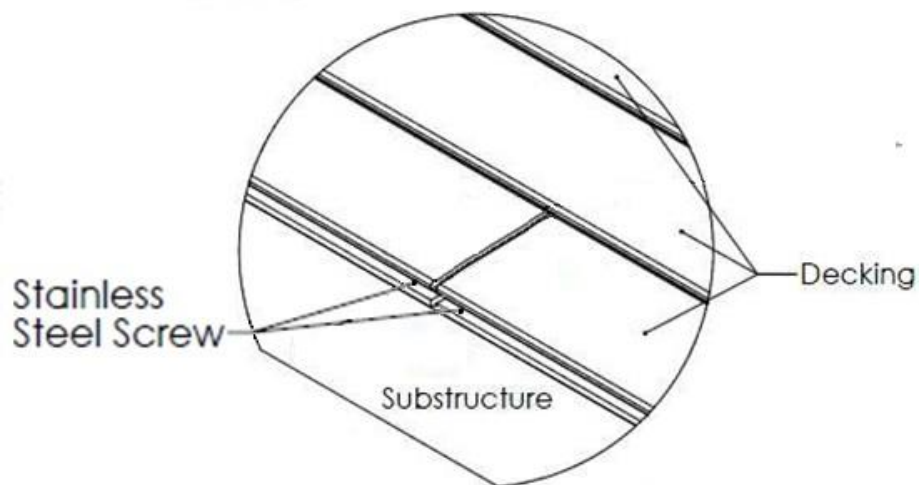



**Note** – Additionally a Plastic Clip needs to be installed over the hard fastening screw for the proper attachment of the next board.

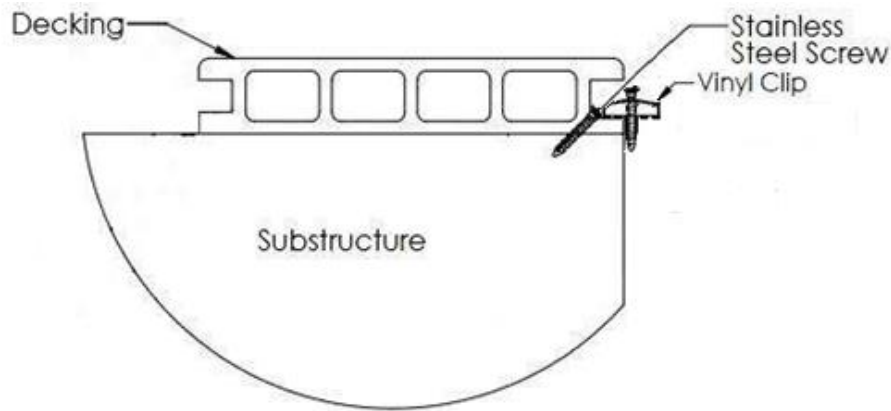

**THIS STEP IS A MUST!**  
**FAILURE TO HARD FASTEN EACH BOARD ON THE CENTER FOR SINGLE BOARD INSTALLATION OR AT THE BUTTING ENDS FOR TWO BOARDS INSTALLATION WILL VOID THE WARRANTY**

**Note** – When installing 3 or more boards next to each other *ONLY* use 12' long boards due to the Expansion and Contraction.

**STEP 4.3** – Pre-set the screw into the clip, securing the screw into the frame substructure but do not tighten the screw onto the clip. Only set the screw half way into the clip so that the next deck board can be installed

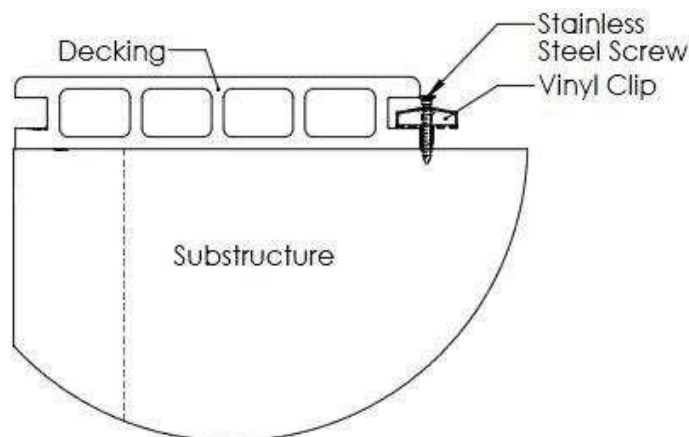



**STEP 4.4** – Install the next deck board at an angle to the first making sure that the deck board is fully rested under the part-way installed clip. If necessary, lightly tap the deck board with a rubber mallet.

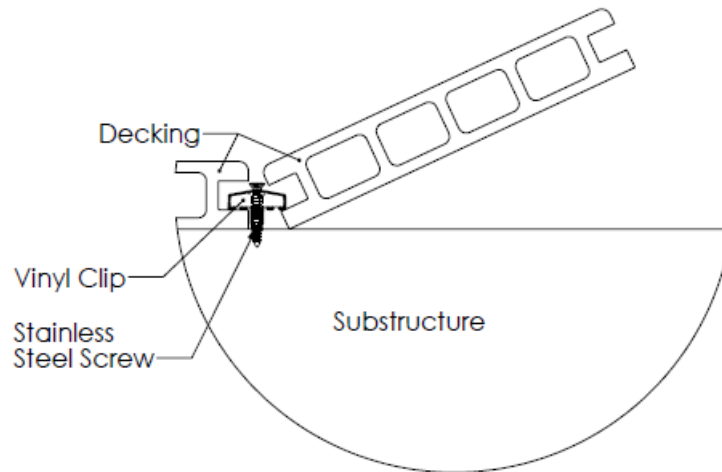

**STEP 4.5** – Once the deck board is seated properly repeat Step 5.2 to install the center screw into the deck board. Install the next clip as show in Step 5.3 to hold the deck board in place. Next, go back to the previously installed deck board and tighten the screw onto the clip to hold down both deck boards.

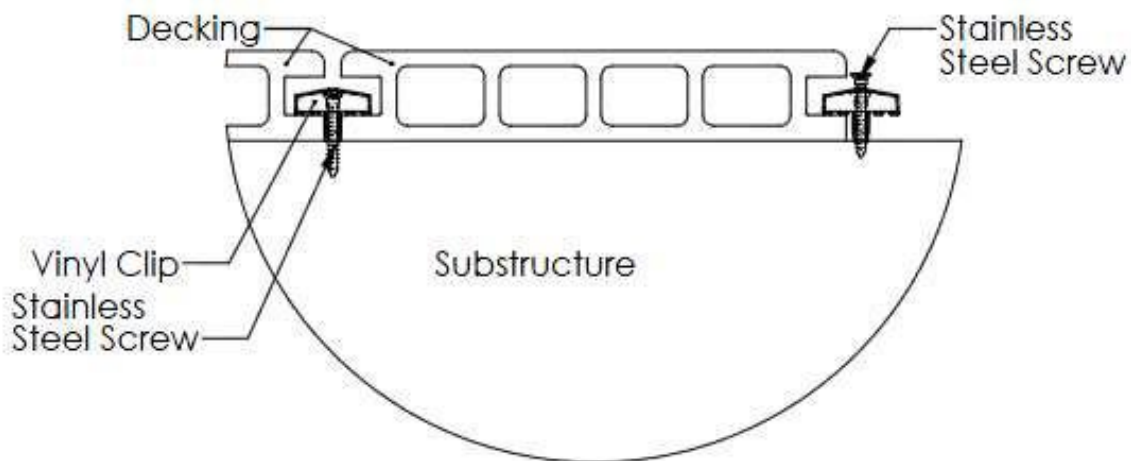

**Note** – Recommend using a narrow head bit to secure the screw between the two boards. If a narrow bit is not used the bit could damage the boards when securing the screws.

**STEP 4.6** – Continue installing deck boards as outlined in Section 5 until deck is finished. A plastic clip must be installed onto each joist to properly secure the deck boards down to the substructure.



**STEP 4.7** – If installing a deck with end-to-end joints make sure that a minimum of two clips are installed at each end-to-end joint. Install two plastic clips at each joint, one clip onto each deck board. Never install one plastic clip across two deck boards. To properly gap the end-to-end joints see Table 1.2 at the beginning of this document. Window shims can be used to help gap the joints of deck boards to provide an even gap throughout installation.

**THIS STEP IS A MUST!**  
**FAILURE TO INSTALL DOUBLE JOIST AND TWO CLIPS AT EACH  
END-TO-END JOINT WILL VOID THE WARRANTY**

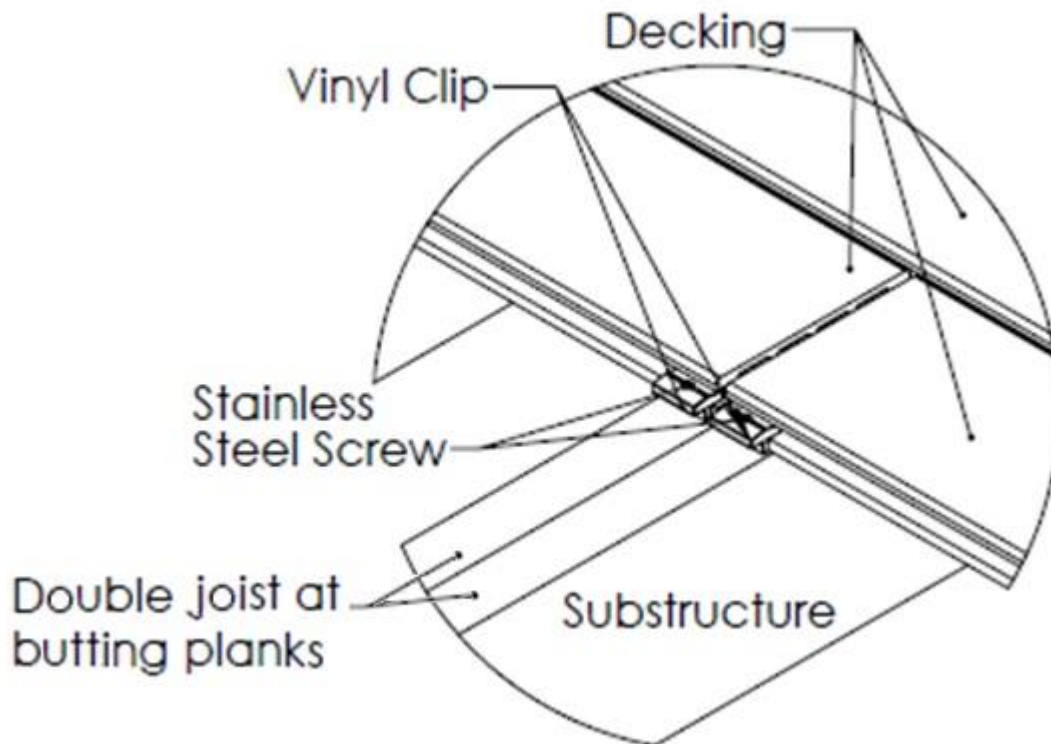



## SECTION 5 – Selecting Finishing Options

Resysta decking allows the installer to choose from two different starting techniques but there is only one finishing technique. The type of installation, including Location, Finishing, and Trimming options, will affect which finish condition can be used to secure the deck board. If installing a deck where the ends of the deck boards will be against a house or wall, use the proper wall gap spacing before securing the deck boards to the substructure.

The only recommended finish options to secure the deck last deck board is identical to the start options described in section of 3.1.

See the notes in Section 6 for the start/finish restrictions of securing the last deck board.

## SECTION 6 – Finishing and Trimming Suggestions

Resysta decking offers many different methods to trim and finish decking that includes covering exposed ends of deck boards, finishing the last board, and covering substructure framing. In addition, Resysta can be installed in patterns to minimize the difficulty of trimming while enhancing the look and appeal of the decking surface. Due to the number of possibilities with Resysta decking only a few finishing options are displayed in the Installation Guide. These finishing and trimming suggestions are not required and are not compressive in this guide.

- 1) All deck boards can be ripped close to a center support and sanded smooth to finish the last board of a decking system. If this is used only start/finish conditions 3.1 and 3.3 can be used to secure the deck board to the substructure.

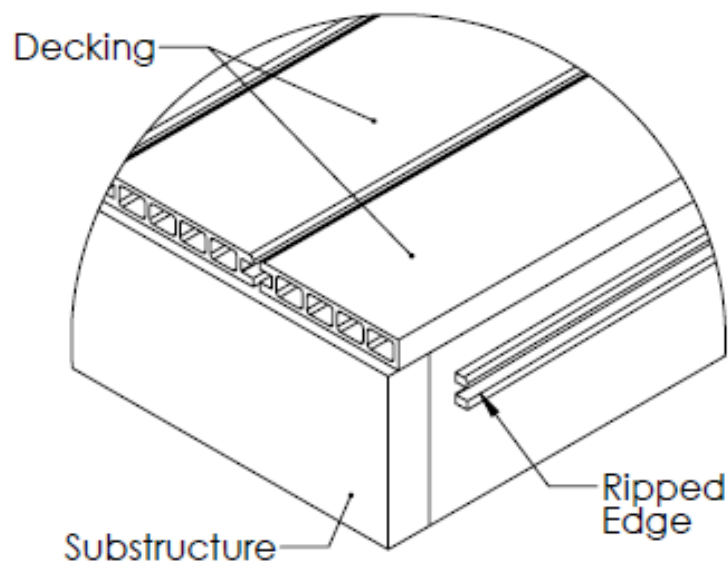

- 2) An Edge Cap profile will fit in the clip pocket of the Gold and Platinum boards to finish out the outside edge of the deck boards. To attach apply UV protected glue in the clip pocket of the deck board. Firmly insert the Edge Cap profile into the clip pocket groove, tap with a rubber mallet if necessary. Once the glue is cured the edge can be sanded to create a seamless finish.

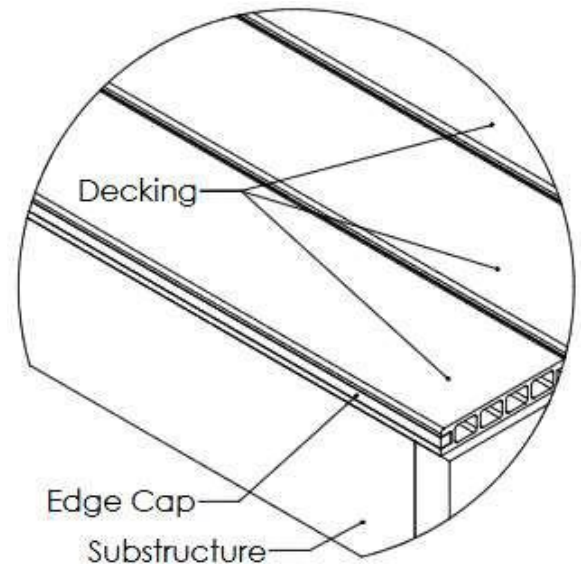
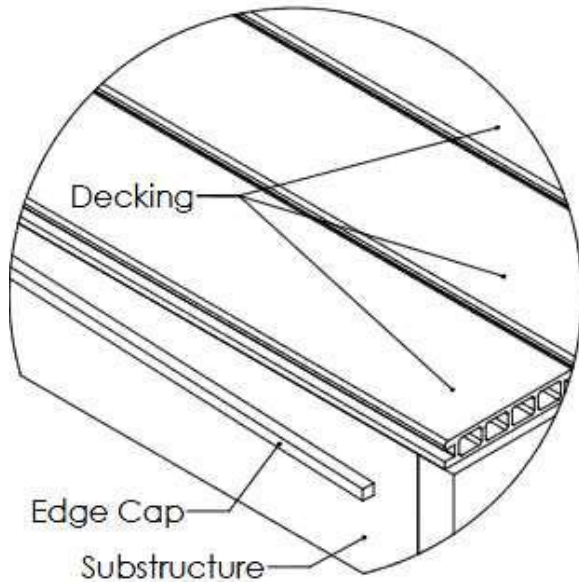

- 1) An End Cap profile can be used to cover the ends of the Gold and Platinum boards and finish the open hollow edge of the deck boards. Route a space to insert the End Cap into the end of the deck board using a 5/8" router bit. Route 1/2" deep into the profile. Cut the End Cap to the appropriate length so it fits the width of the decking board. To attach apply UV protected glue in the routed space of the deck board. Firmly insert the End Cap profile into the routed space, tap with a rubber mallet if necessary. Once the glue is cured the end of the board can be sanded to create a seamless finish.

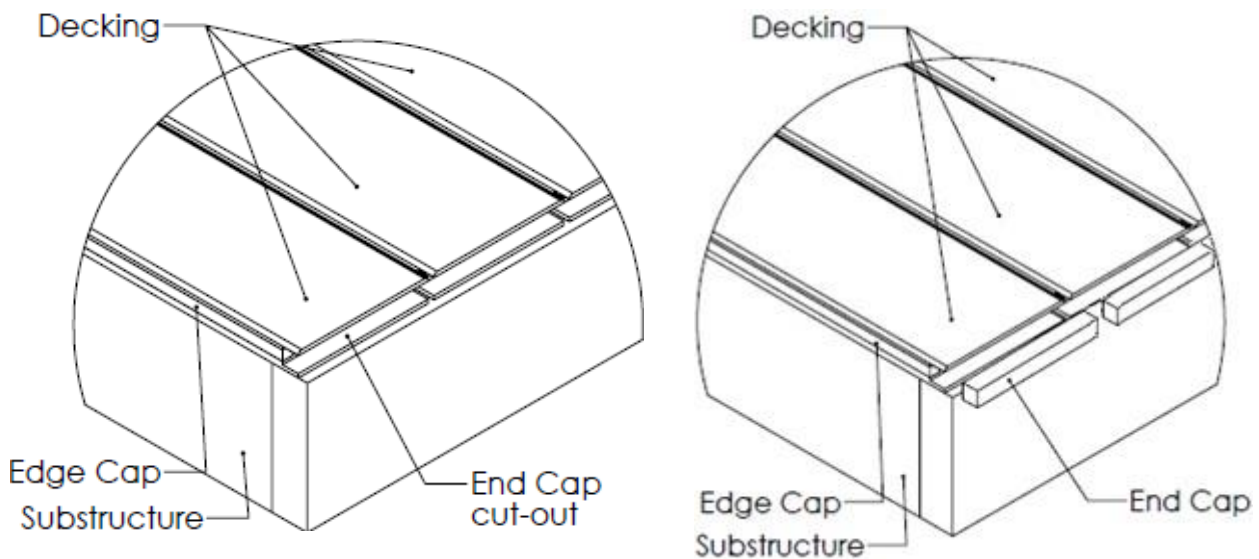

**Note** - This step should be done prior to the installation of the decking board but it is highly recommended to order the boards finished by pre-finisher.

- 2) Fascia board can be used to cover the substructure as well as the ends of the deck board and/or the last board. The fascia board can be used to picture frame the deck by miter cutting the ends of the fascia board at a 45 degree angle. To use this technique properly and cover both the substructure and deck boards, use the gap guide in Table 1.2 to properly Gap the boards with the fascia board. Treat the fascia board as a solid wall when gapping. Fascia board can be secured by counter sinking the screws and attaching into the substructure. Recommend using #10 x 1-1/2" stainless steel screw and attaching 3 screws every 12" to secure fascia board to the substructure.

**Note** – If you do not want a gap at the corners of the fascia board it is recommended to install without mitering the corners and using an overlapping joint.

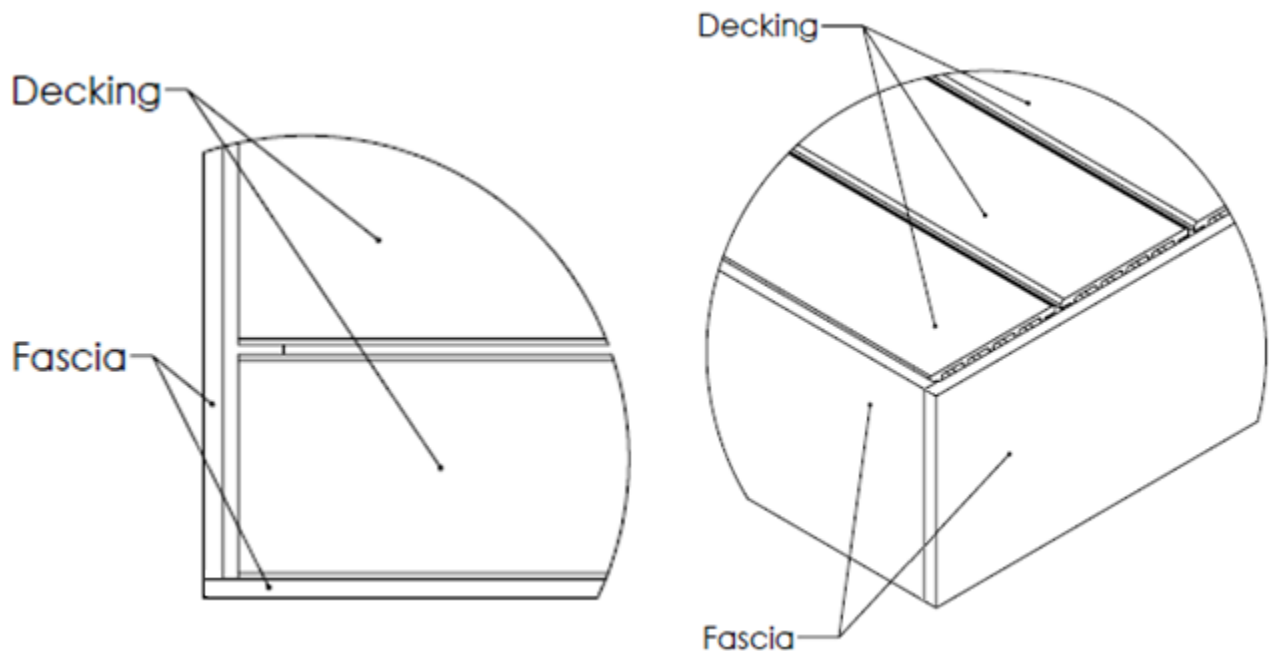



- 3) Patterns can also be made with the Resysta decking to minimize the difficulty of trimming the deck or to enhance the look of the decking. A simple picture frame pattern can be made where the clip pocket of the decking is exposed on all sides of the deck.

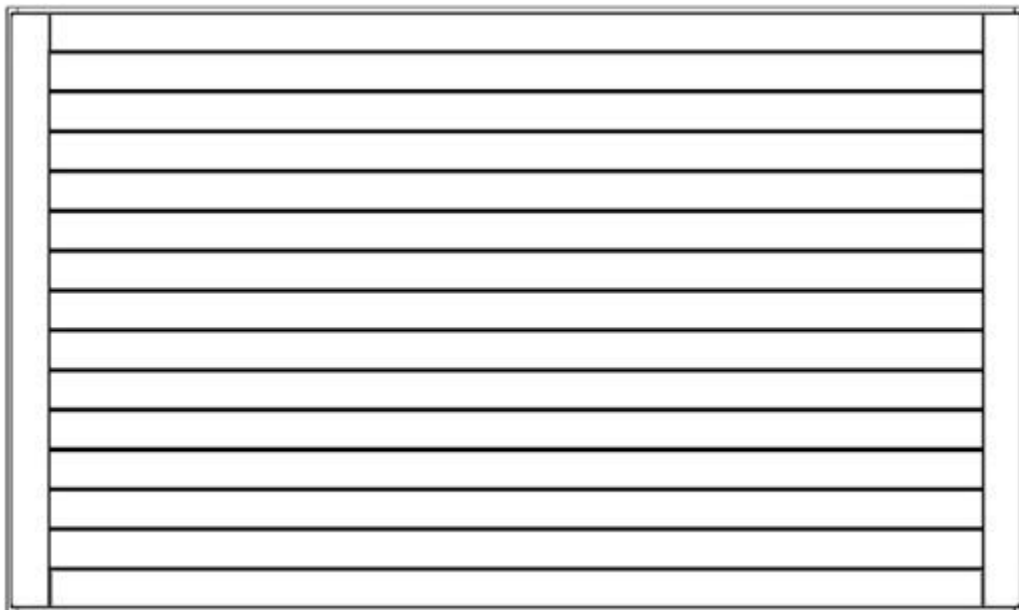
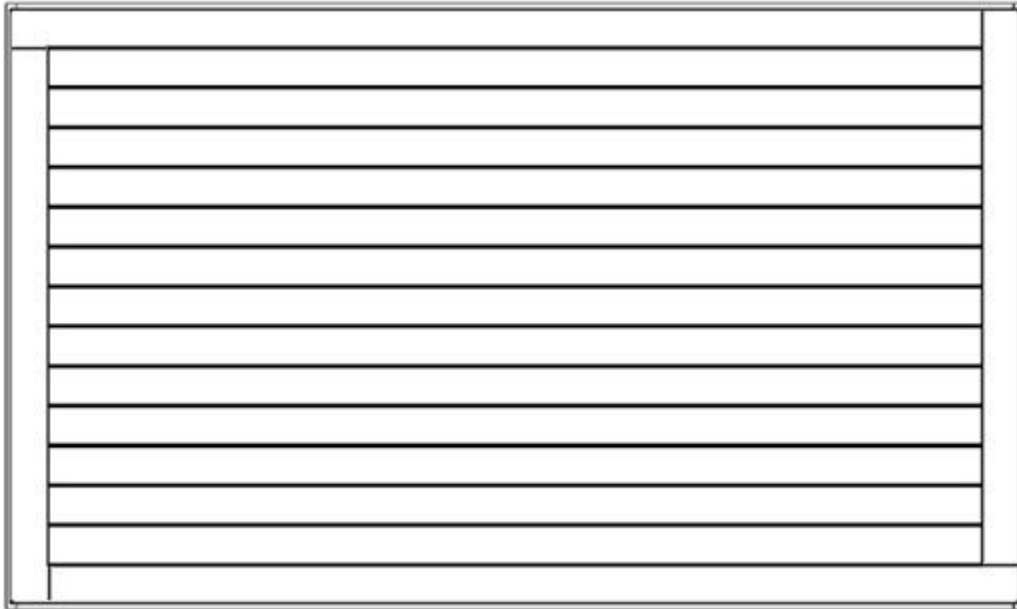



## **SECTION 8 – Stain and Sealer System**

Resysta recommends using approved water based stain and sealer system.

### **Safety Warning**

Resysta Products do not present an inhalation, ingestion, or contact health hazard unless subjected to operations such as sawing, sanding, or machining which result in the generation of airborne particulate. This product contains crystalline silica. Respirable crystalline silica limits are specified by OSHA. Exposure to respirable (fine) silica dust depends on a variety of factors, including activity rate (e.g. cutting rate), method of handling, ventilation, environmental conditions (e.g. weather conditions, workstation orientation), and engineering control measures used. Exposures to respirable crystalline silica above limits established by OSHA are not expected during the normal use of this product. Crystalline silica, has been shown to cause silicosis, and has been identified by the State of California, IARC and NTP as a known human carcinogen. The risk of developing silicosis is dependent upon the exposure intensity and duration. It is recommended that a NIOSH approved particulate respirator be worn whenever working with this product results in airborne dust exposure.

Please direct product inquiries to:

Resysta North America, Inc.

4035 Cheyenne Ct.

Chino, CA. 91710

Tel: 909-393-2888

Email: [info@resystausa.com](mailto:info@resystausa.com)